

## SD-3

### MONITOR OIL/DIESEL TEMPERATURE & HUMIDITY

Water ingress can cost more than a new oil fill-up. Emulsified and free water can cause huge problems to your fuel or hydraulic systems. It can increase the rate of oxidation by more than ten times and bearings can lose 75% of their service life from water ingress - and all this before the oil even begins to look cloudy. Ensure your oil or fuel is always below saturation point; if emulsified or free water begins to form, immediate action can be taken.

Even when dissolved in oils or fuels, water attacks the base stock, any additives and the machine itself. Water can even carry organisms that have the potential to disable and damage your hydraulic systems.

The SD-3 provides a state-of-the-art sensor that detects any level of free water or emulsified water in real-time. The Auto Control Systems SD-3 can be installed in any lubrication, hydraulic or fuel system, on any type of machine. Whether mounted along a hose or pipe, or even below the fluid level in a tank or reservoir, the SD-3 measures the relative humidity (0 - 100%) and the temperature from -20 - 100°C (or °F) and displays it on the IP 67 rated colour screen in real-time. Alarms can be custom set to allow for any

application and protection level so you can be sure that you will catch any problems before they damage your equipment.

Oil sampling to check for water ingress can be time consuming and costly. Missing just one scheduled check can result in machine failure which costs your business money in both downtime and parts replacement. Even regular checks will sometimes fail to catch a new problem before it's too late. Used in conjunction with a pro-active maintenance schedule, the real-time monitoring ability of the

SD-3 can prevent this from happening. With the ability to read up to three sensors at once, the SD-3 has the potential to save you tens of thousands of dollars.

With more inputs and outputs available in the system, we can even add functionality as you need it. Or, to step it up a level, we have the SD-7, an incredible system with even more possibilities including a screen that



can handle 100g's of shock, almost endless inputs & outputs and can work in conjunction with the SD-3.

Auto Control Systems specialty is to design and build systems that make monitoring, understanding and control of equipment easier. This gives you the power to better recognise potential problems and prevent failures before they cost you time and money.

This is the strength of the SD-3. Our system sensor works through the intelligent combination of a thin film capacitive measurement element and smart algorithms to provide highly accurate feedback on the condition of your oil.

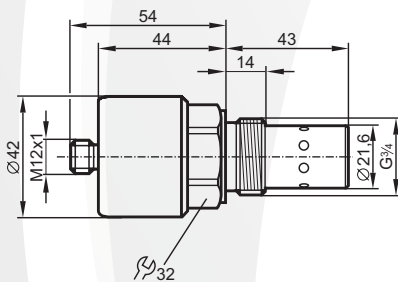

Sensor Technical Data	
Process Connection	G 3/4
Pressure Resistance [bar]	10
Output Function [mA]	4 - 20
Ingress Protection	IP 67
Oil Temperature Range [°C]	-20 - 100
Ambient Operating Temperature [°C]	-20 - 85
Operating Voltage [VDC]	9 - 33
Current Consumption [mA]	< 60
Measuring Resolution	
Relative Humidity [%]	1
Temperature [K]	0.1
Measuring Accuracy	
Relative Humidity [%FS*]	±3
Temperature [%FS*]	±2
Materials (wetted parts)	aluminium, HNBR, polyurethane resin, epoxy resin
EMC	EN 13309:2000-11

\*FS = Full scale

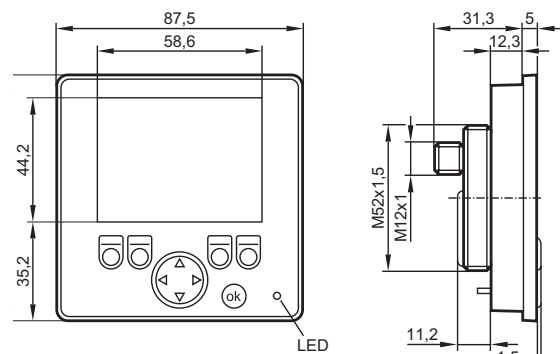

Display Technical Data	
Operating Voltage	9 - 33
Current Consumption	< 70 (max)
Processor	Freescle PowerPC 5517E, 50MHz
Memory (total)	592K RAM, 1536K Flash
CAN	CAN interface 2.0 A/B, ISO 11898
LED	Two colour (red/green)

**To arrange a demo or to talk with Auto Control Systems about fleet and volume purchases, please call +618 9258 4555 or email sales@autocontrols.com.au**